

## Sintered Elements

- Made of SS316 element (powdered metal).
- Made of 3316 sintered.
- High heat resistance and thermal stability up to 900°F (482°C).
- Low-pressure drop with high permeability.
- Self-supporting seamless element for shape-stability.

Designator	Normal Pore Size (μm)	Pore Size Range (μm)	Element Porosity
05	05	05 to 2	17%
2	2	1 to 4	25%
7	7	5 to 10	30%
15	15	11 to 25	36%
60	60	50 to 75	44%
90	90	75 to 100	46%

## Flow Data at 70°F (20°C)

Sintered Element Designator	Pressure Drop, psig(bar)			Inlet Pressure, psig(bar)		
	10 (0.68)	50 (3.4)	100 (6.8)	5 (0.34)	10 (0.68)	15 (1.0)
	Water Flow (Std L/min)			Air Flow, std L/min (std ft <sup>3</sup> /min)		
05	0.03	0.15	0.45	1.1	1.7	3.4
2	0.30	0.91	1.5	5.6	11	17
7	0.37	1.1	1.8	14	25	34
15	0.45	1.3	2.1	22	36	42
60	0.56	1.8	2.6	48	62	68
90	0.75	1.8	2.2	51	62	73

## 3000PSIG (206bar) Micron Inline Filters

### Ordering Information and Table of Dimensions

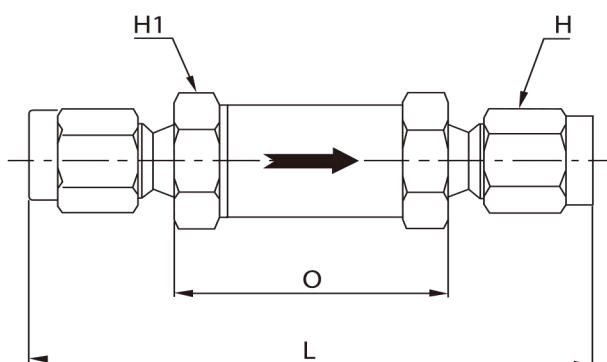

Basic Ordering Number		Orifice In.(mm)	End Connection		Dimensions			
			Inlet	Outlet	L	O	H	H1
IFT1	I-2T	0.094 (2.4)	1/8" I-LOK		59.7	29.2	11.1	14.3
	M2N		1/8" Male NPT				-	
	F2N		1/8" Female NPT				-	
	I-3M		3mm I-LOK				12.0	
IFT2	I-4T	0.187 (4.8)	1/4" I-LOK		75.2	39.7	14.3	19.0
	M4N		1/4" Male NPT				-	
	F4N		1/4" Female NPT				-	
	I-6M		6mm I-LOK				14.0	
IFT3	I-6T	0.281 (7.1)	3/8" I-LOK		81.8	43.2	17.4	25.4
	M6N		3/8" Male NPT				-	
	F6N		3/8" Female NPT				-	
IFT4	I-8T	0.409 (10.4)	1/2" I-LOK		86.9	43.2	22.2	25.4
	I-10M		10mm I-LOK				19.0	



# IFT Series Micron Filter

## MICRON FILTERS

3000PSIG (206bar) Micron Inline Filters

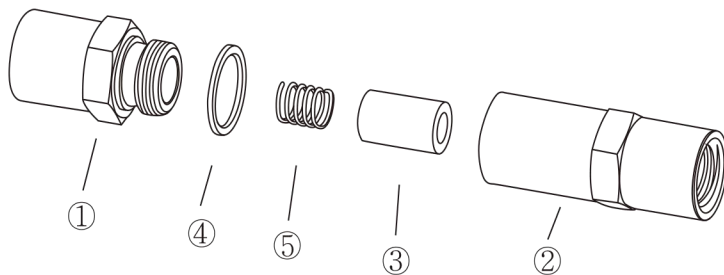

6000PSIG (413bar) Micron Tee Filters

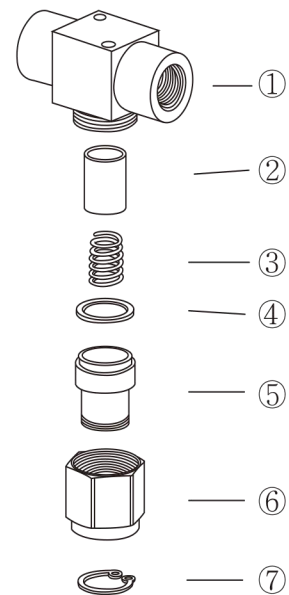

Components	Valve Body Material Grade / ASTM Specification		
		SS316	BRASS
1	Body		BRASS / B16
2	Bonnet		BRASS / B16
3	Filter Elements	SS316 Sintered	
4	Gasket	Silver-plated SS316	Aluminum / B29
5	Spring	SS302	
6	*Cap Nut	SS316	BRASS / B16
7	*Snap Ring	SS316	BRASS / B16

\*\*6-7 Only Tee Filter

### Features

- Trap system contaminants to maintain system purity.
- Clean fluid(gas and liquid) application pressure-carrying
- Self-supporting structural element suitable pressure-carrying
- Uniform distribution with defined permeability and porosity.
- Replaceable Filter elements and sintered.
- Types of filter are available ; Tee Filter and In-Line Filter.
- In-Line / Tee Filter are applicable where space is limited.

### Operation

- Filtration element prevents contaminants from passing through if they are bigger than the pore size.
- As contaminants are trapped, the pressure drop becomes greater.
  - When pressure drop becomes too high, the element requires replacement.
  - Filter element requires replacement more often for unclean fluids.

### Factory Test and Packaging

- Every Filter is factory tested (taken a factory test) @1000 psig (69bar) for no detectable leakage with a liquid leak detector.

## Ordering Information

### 1. Valve Designator

- IFT1 : 2.4mm Orifice
- IFT2 : 4.8mm Orifice
- IFT3 : 7.1mm Orifice
- IFT4 : 10.4mm Orifice

$$\frac{\text{IFT1}}{1} - \frac{1}{2} - \frac{6T}{3} - \frac{15}{4} - \frac{S}{5}$$

### 2. End Connection

I : I-LOK TUBE FITTING    M : Male Pipe Thread    F : Female Pipe Thread

### 3. Size Designator

Thread(in)	1/8	1/4	3/8
Designator	2N(R)	4N(R)	6N(R)

Inch Tube	Tube O.D	1/8	1/4	3/8	1/2
	Designator	2	4	6	8
Metric Tube	Tube O.D	3mm	6mm	10mm	12mm
	Designator	3M	6M	10M	12M

### 4. Filter Element Designator :

- 0.5 : 0.5 Micron
- 2 : 2 Micron
- 7 : 7 Micron
- 15 : 15 Micron
- 60 : 60 Micron
- 90 : 90 Micron

### 5. Body Material :

SS316 :                    /    BRASS :

## 600PSIG (413bar) Micron Tee Filters

### Ordering Information and Table of Dimensions

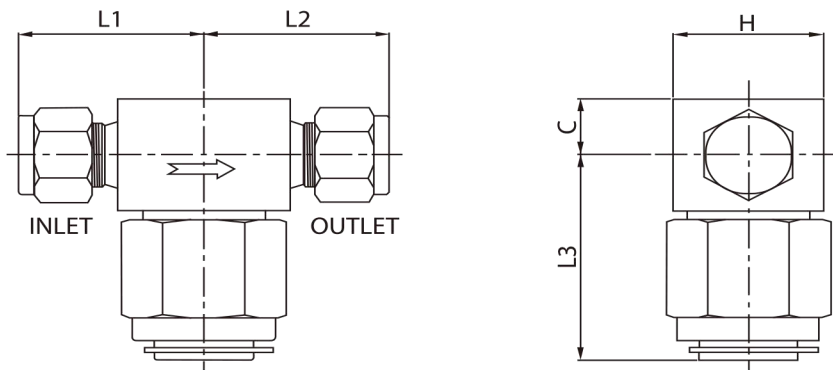

Basic Ordering Number		Orifice In.(mm)	End Connection		Dimensions				
			Inlet	Outlet	L1	L2	L3	C	H
IFT6	F-2N	0.173 (4.4)	1/8" Female NPT		25.0	25.0	38.8	11.0	28.5
	M-4N		1/4" Male NPT		25.5	25.5	38.8	11.0	28.5
	F-4N		1/4" Female NPT		27.0	27.0	38.8	11.0	28.5
	F-6N		3/8" Female NPT		27.0	27.0	41.0	12.7	28.5
	F-8N		1/2" Female NPT		31.0	31.0	44.0	15.8	31.75
	I-4T		1/4" I-LOK		33.0	33.0	38.8	11.0	28.5
	I-6T		3/8" I-LOK		36.2	36.2	38.8	11.0	28.5
	I-8T		1/2" I-LOK		38.7	38.7	38.8	11.0	28.5

## Ordering Information

$\frac{\text{IFT6}}{1} - \frac{\text{I}}{2} - \frac{\text{6T}}{3} - \frac{\text{15}}{4} - \frac{\text{S}}{5}$

### 1. Valve Designator

- IFT6 : Tee Filter Type

### 2. End Connection

I : I-LOK TUBE FITTING

M : Male Pipe Thread

F : Female Pipe Thread

### 3. Size Designator

<b>Thread(in)</b>	1/8	1/4	3/8
<b>Designator</b>	2N(R)	4N(R)	6N(R)

<b>Inch Tube</b>	Tube O.D	1/8	1/4	3/8	1/2
	Designator	2	4	6	8
<b>Metric Tube</b>	Tube O.D	3mm	6mm	10mm	12mm
	Designator	3M	6M	10M	12M

### 4. Filter Element Designator

- 0.5 : 0.5 Micron

- 2 : 2 Micron

- 7 : 7 Micron

- 15 : 15 Micron

- 60 : 60 Micron

- 90 : 90 Micron

### 5. Body Material

SS316 : S / BRASS : BS