

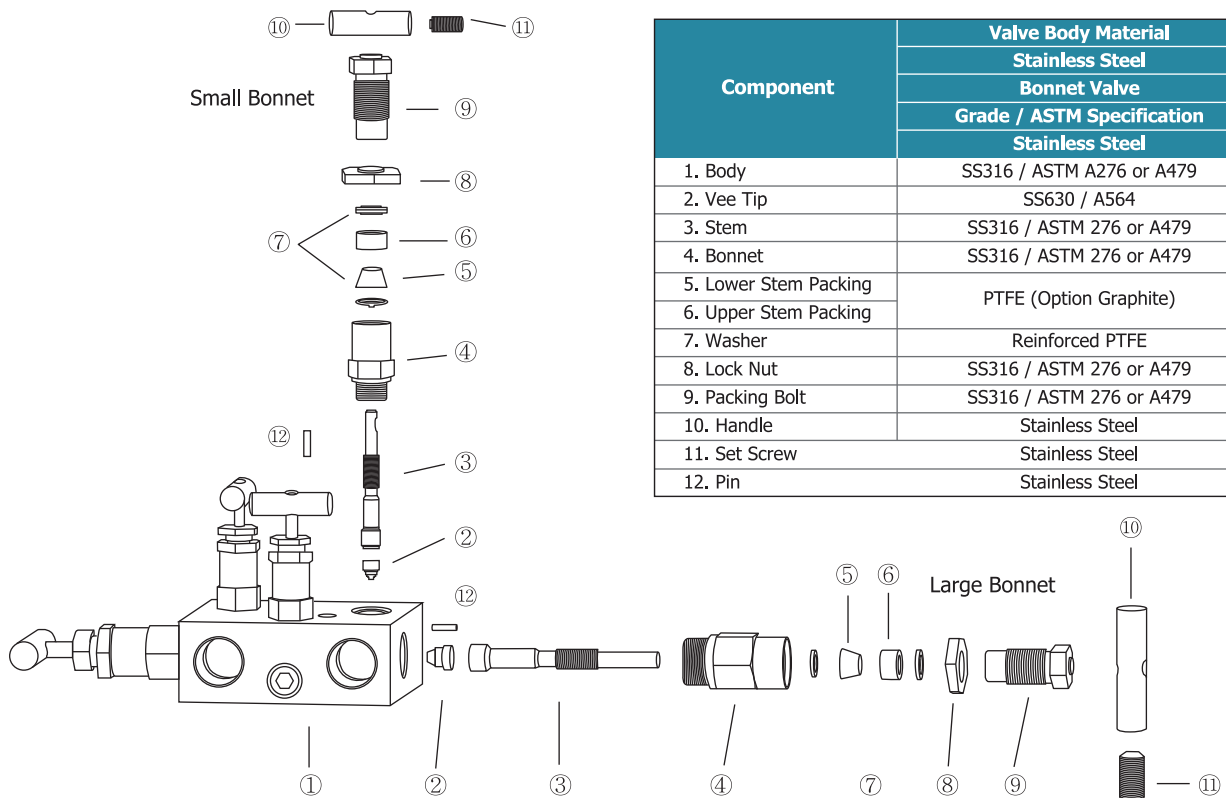

# SMV Series

## Manifold Valves

### 6000PSIG(413BAR) Instrument Manifold Valve



Component	Valve Body Material
	Stainless Steel
	Bonnet Valve
Grade / ASTM Specification	
Stainless Steel	
1. Body	SS316 / ASTM A276 or A479
2. Vee Tip	SS630 / A564
3. Stem	SS316 / ASTM 276 or A479
4. Bonnet	SS316 / ASTM 276 or A479
5. Lower Stem Packing	PTFE (Option Graphite)
6. Upper Stem Packing	
7. Washer	Reinforced PTFE
8. Lock Nut	SS316 / ASTM 276 or A479
9. Packing Bolt	SS316 / ASTM 276 or A479
10. Handle	Stainless Steel
11. Set Screw	Stainless Steel
12. Pin	Stainless Steel

#### Features

- Pressure rating up to 6000psig (413bar)@(38°C).
- Temperature rating up to 1200°F (648°C) with optional Grafoil packing.
- Flange seal groove meets the design requirement of MSS- SP- 99.
- Body materials are available in 316 stainless steel, carbon steel.

## Technical Data

Packing Material	Body Material	Temperature	Pressure Rating @ 100□	Pressure Rating @ Max. Temperature
PTFE	Stainless Steel	-65□ ~ -450□ (-54□ ~ 232□)	6000 psig	4130psig @450□ (285bar @ 232□)
	Carbon Steel	-20□ ~ -350□ (-29□ ~ 176□)		5230psig @450□ (360bar @ 176□)
Graphite	Stainless Steel	-65□ ~ -1200□ (-54□ ~ 648□)		1715psig @1200□ (118bar @ 648□)
	Carbon Steel	-20□ ~ -350□ (-29□ ~ 176□)		5230psig @350□ (360bar @ 176□)

## Factory Test and Packaging

- Every valve is factory tested(taken a factory test) with nitrogen @ 1000 psig (69 bar)
- For leakage at the seat to a maximum allowable leak rate of 0.1 SCCM.
- Every valve is cleaned and packaged in accordance with SHINILACE cleaning standard.

## Ordering Information and Table of Dimensions

	Basic Ordering Number	End Connections		Orifice mm(in)	
		Process	Instrument		
Remote Mount	SMV2-8N	1/2" Female NPT		3.2 (.126)	
	SMV5-8N			6.4 (.251)	
	SMV2-F1				
Direct Mount	Single Flange	1/2" Female NPT to Flange Flange design of MSS-SP-99		3.2 (.126)	
				SMV5-1F-8N	6.4 (.251)
				SMV3-F1-8N	
	Double Flange	Flange to Flange Flange design of MSS-SP-99		6.4 (.251)	
					SMV5-F2-8N
	Vertical	SMV2-DM-8N	1/2" Female NPT to Flange Flange design of MSS-SP-99		3.2 (.126)
					SMV3-DM-8N
SMV5-DM-8N					6.4 (.251)
					5.0 (.196)

## Remote Mount

### • 2-Valve Manifolds

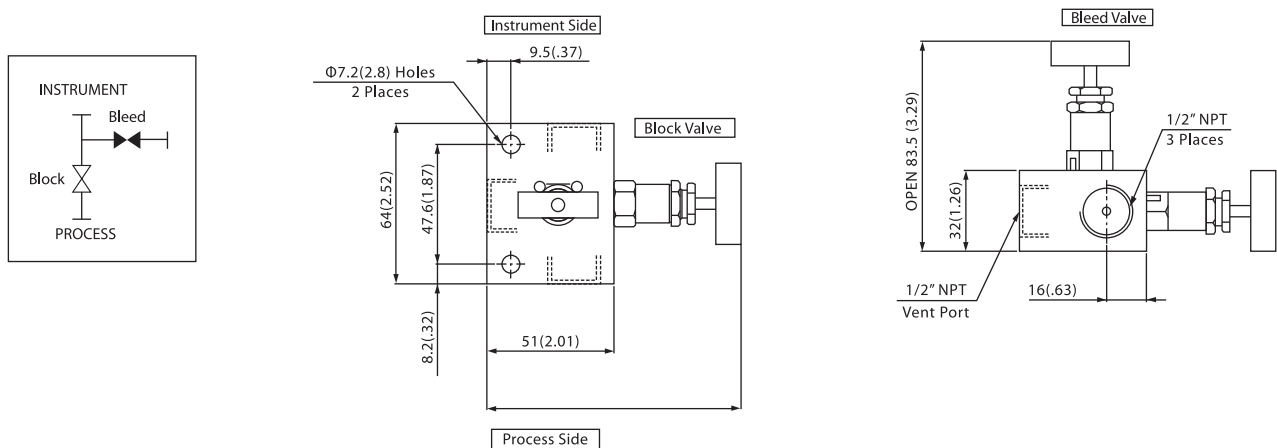

### • 3-Valve Manifolds

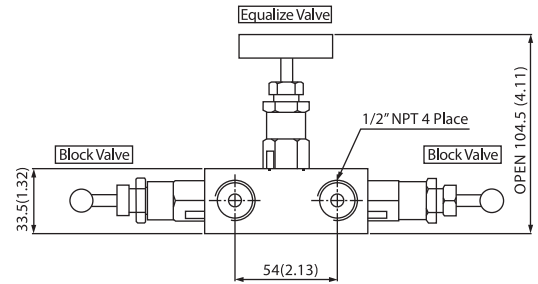
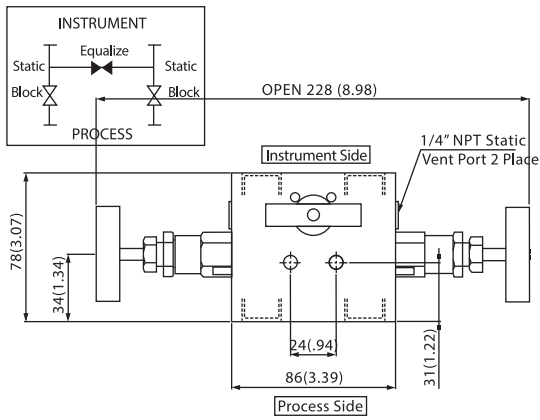

### • 5-Valve Manifolds

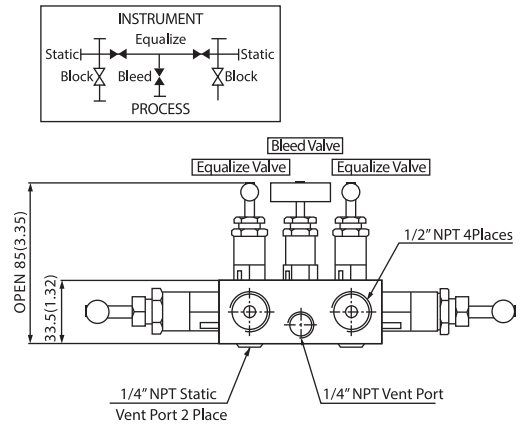
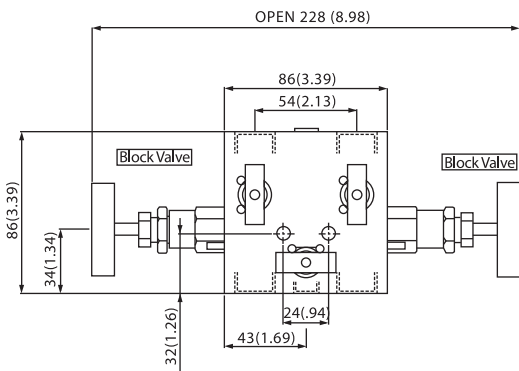

## Single Flange Direct Mount

### • 2-Valve Manifolds

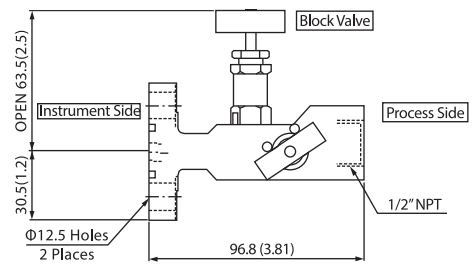
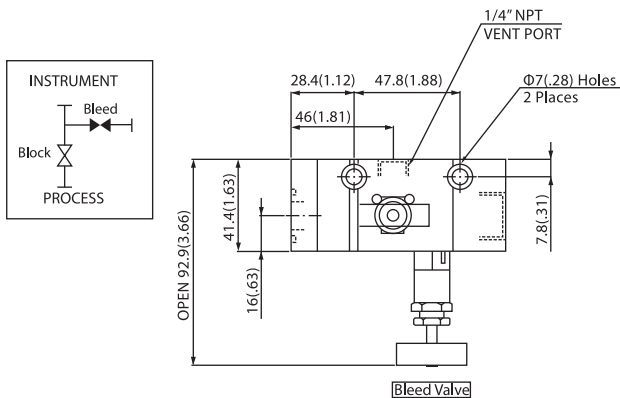

### • 3-Valve Manifolds

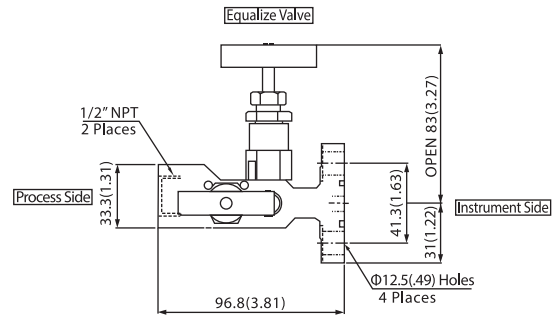
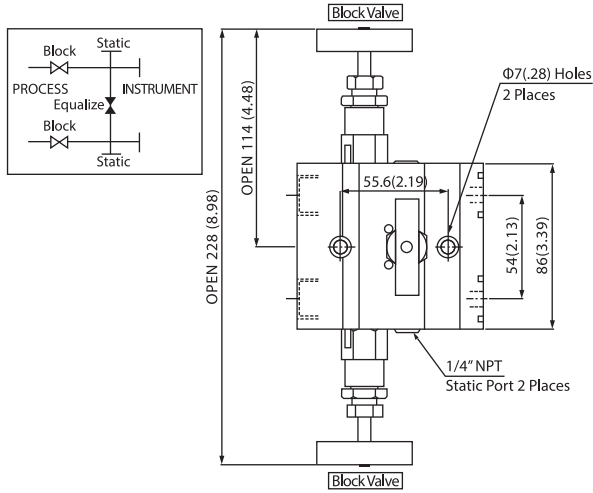

### • 5-Valve Manifolds

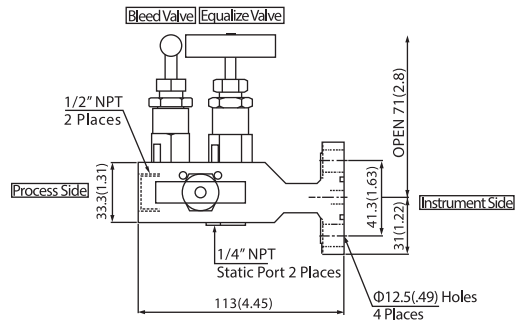
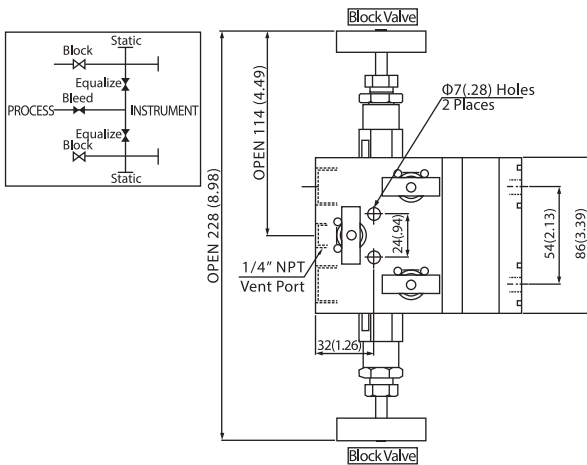

## Double Flange Direct Mount

### • 3-Valve Manifolds

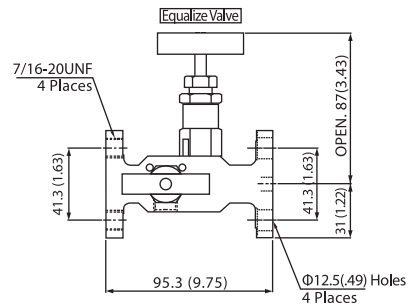
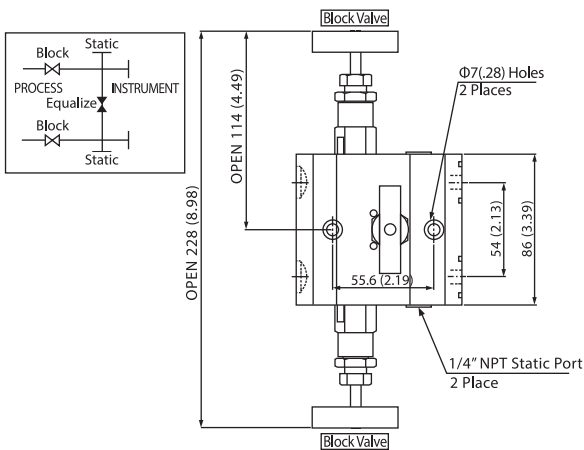

### • 3-Valve Manifolds

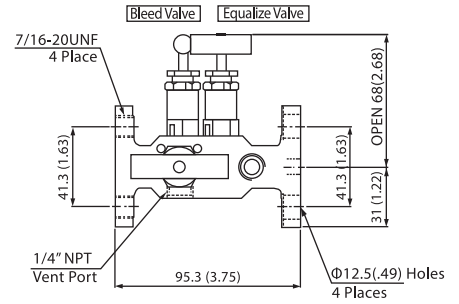
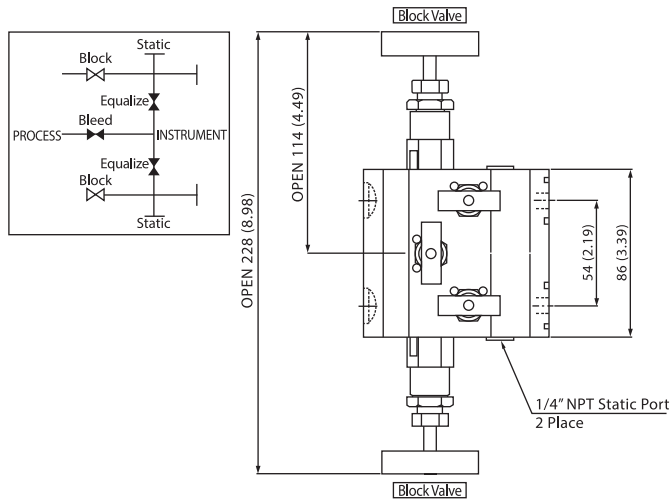

### Vertical Direct Mount

### • 2-Valve Manifolds

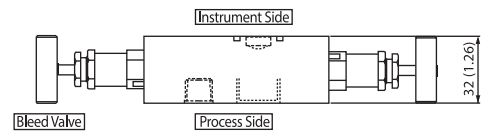
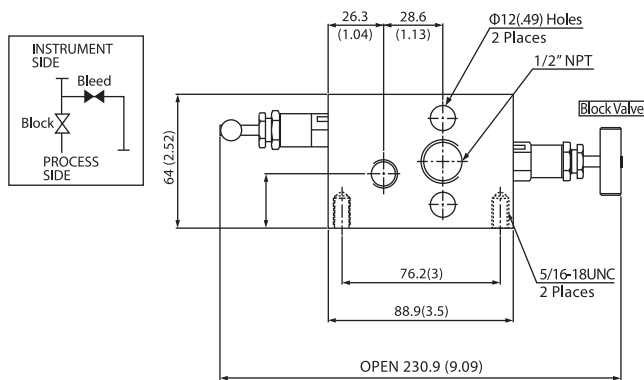

### • 3-Valve Manifolds

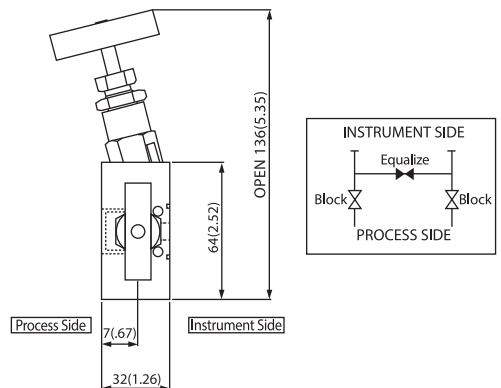
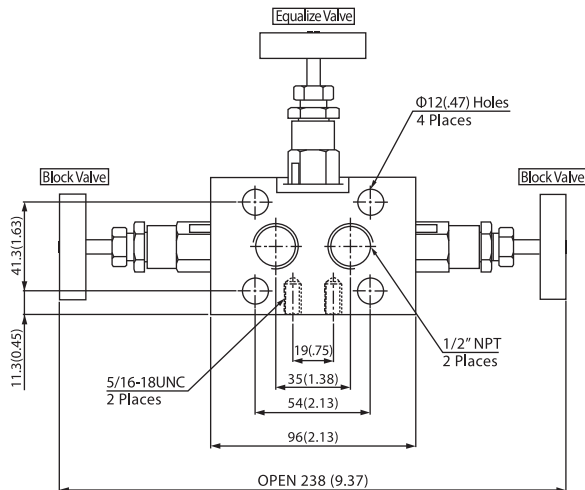

## • 5-Valve Manifolds

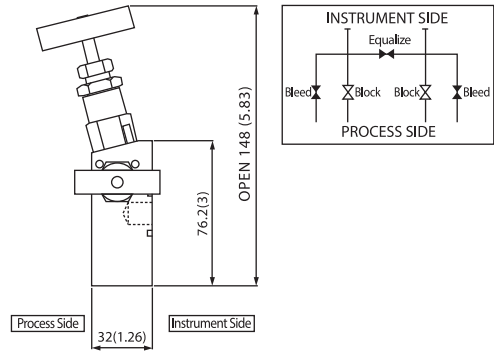
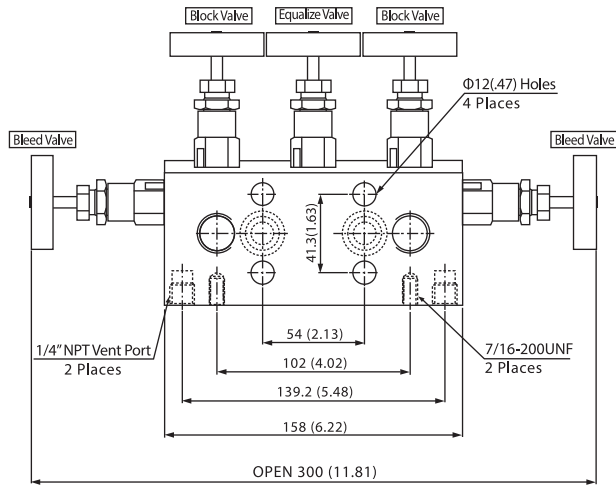

## • 5-Valve Manifolds

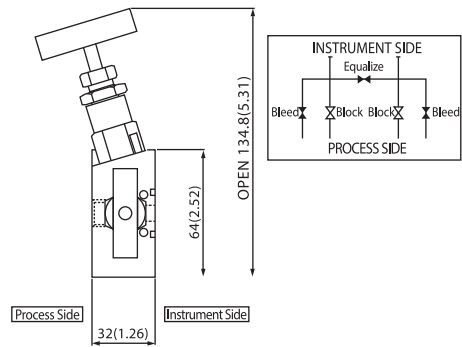
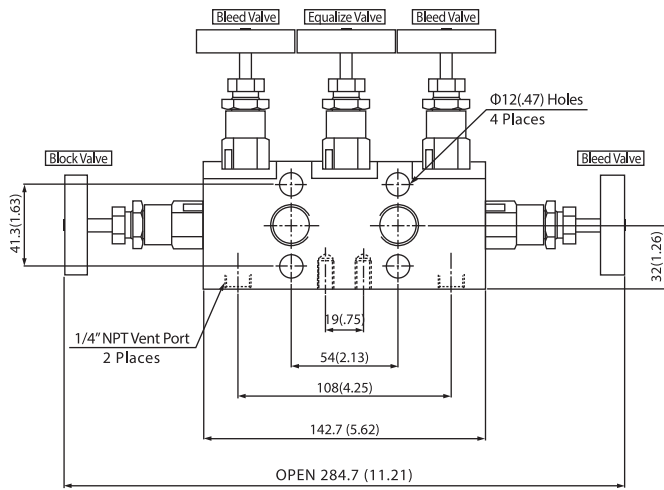

## SGV Series Gauge Root Valve

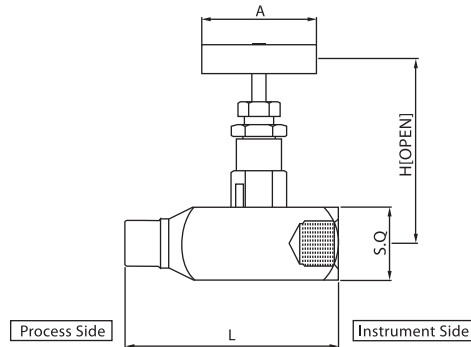
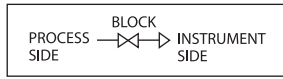

### Ordering Information and Table of Dimensions

Basic Ordering Number	End Connections		Dimensions			
	Process	Instrument	L	H	A	S.Q
SGV1-MF-8N	Male NPT 1/2"	Female NPT 1/2"	90	87	50	32
SGV1-MG-12N	Male NPT 3/4"	Female NPT 1/2"				

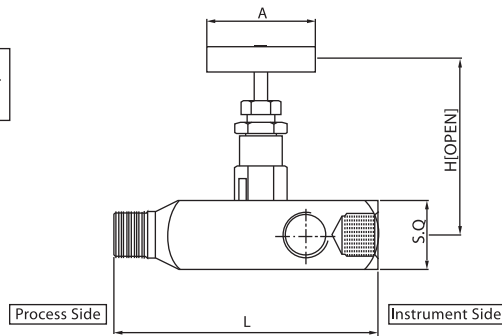
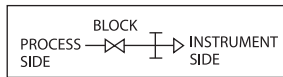

### Ordering Information and Table of Dimensions

Basic Ordering Number	End Connections		Dimensions			
	Process	Instrument	L	H	A	S.Q
SGRV1-MF-8N	Male NPT 1/2"	Female NPT 1/2"	136	87	50	32
SGRV1-MF-12N	Male NPT 3/4"	Female NPT 1/2"				

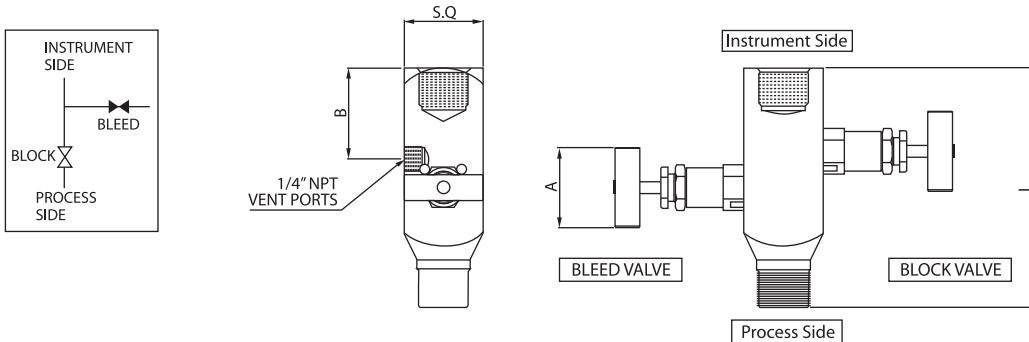

### Ordering Information and Table of Dimensions

Basic Ordering Number	End Connections		Dimensions				
	Process	Instrument	L	B	H	A	S.Q
SGV2-MF-8N	Male NPT 1/2"	Female NPT 1/2"	96	36.2	141.1	50	38.1